

**Title: Protecting Treasures**

Grade level targeted: (5-8)

**Writer(s) and e-mail address(es):** Jamie Hall (Jdhall@wcpss.net)

**Goals/Standards:**

**National Science Education Standards:**

Physical Science Content Standard E: As a result of activities in grades 5-8, all students should develop abilities of technological designs and understandings about science and technology

**North Carolina Standards:**

**Goal 2: The learner will demonstrate an understanding of technological design.**

**Success Indicator:**

Students will create a functional alarm system that will protect a treasure (an item that is valued by the student), from being taken by a thief.

**Background knowledge:**

The Sun - Up Alarm can be used to provide a audible alarm for when the sun comes up or it can be used in a dark area and detect when a light comes on. It can also be used to detect a light beam, headlights etc. The circuit works as follows. The phototransistor is very sensitive to light. (Any phototransistor will work fine) The sun shining on this device will provide a high to one of the NAND gates. This will cause another NAND gate to oscillate which will drive another gate to output a 100hz tone. The transistor provides drive for the speaker. (Discover Circuits)

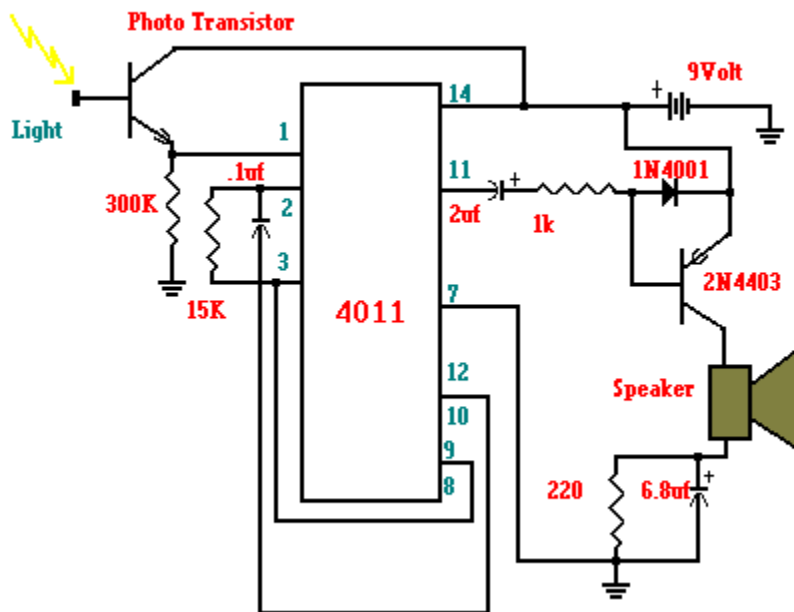

### Engagement

You have inherited a precious item that is very valuable. It has been in your family for hundreds of years. You need to build an alarm circuit to protect your heirloom. Using the Sun-Up circuit you will construct a safe place for your precious item.

### Materials:

1. Wire stripper
2. Needle nose pliers
3. Scissors
4. Hot glue gun
5. Electronic components
6. Wire
7. Crimp tool
8. Screwdriver
9. Utility knife
10. Continuity tester
11. Boxes (1 per group or 1 per person) with dimensions of at least 14'' x 5'' x 5''
12. Screws
13. Cardboard pieces
14. 9 volt batteries one per circuit
15. Construction paper

### **Procedure:**

1. Copy the diagram of the circuit. Students will use this as a guide to build their circuit. The circuit will be built and attached to a flat piece of cardboard.
2. After building the circuit, check the continuity at each connection point in the circuit to insure electron flow. Use a continuity tester before you connect any power source to your circuit. Use the continuity tester only to test your conductance at each bare wire point.
3. Before placing the circuit in the box the student should change the box so that it is visually attractive. They can use construction paper, paint, anything that they feel appropriate. Try to guide students to build a box that may look like it will hold something of value.
4. Inside of the box students will build a special place for their heirloom!
5. Students will strategically place the circuit inside the box. It will have to be in a place where the light will hit the sensor when the door is open.
6. Using the hot glue gun with assistance from the teacher, students will glue their circuit in the box.
7. When the circuit is in place they will place their heirloom into the box in the designated area. They will then test their alarm circuit.

### **Follow-up**

1. **Share what you did.**
  - A. **As you were building what strategies did you come up with that helped you?** (answers will vary, testing the circuit, knowing the size of their object, using the continuity tester)
  - B. **What problems did you find as you tested your circuit?** (the circuit did not work properly)
  - C. **Where did you place your alarm circuit in your box?** (top, bottom, corner)
2. **Process what's important.**
  - A. **What parts of the circuit did you test?** (each bare wire point)
  - B. **Why did you place the heirloom in your particular spot?** (so burglars have a more difficult time to steal the object, answers will vary)
  - C. **What problems came up as you were building your circuit?** (no electron flow, answers will vary)
  - D. **What are the design flaws in your alarm circuit?** (box has to be kept in a lighted area)
3. **Generalize to your life.**
  - A. **How do banks protect a person's money and belongings?** (with various types of alarm systems and safes)
  - B. **How can you use this circuit at home?** (using it as a night light or in other small appliances)
  - C. **How can you protect larger items such as cars, motorcycles, bikes, or skateboards?** (by using other types of alarms such as motion detectors, sound detectors, or alarms that are sensitive to touch)

**4. Apply what you learned**

**A. What other circuits could you use to protect valuables?** (alarms such as motion detectors, sound detectors, or alarms that are sensitive to touch)

**B. Where else could you find a circuit in your home that would act like the one you built?** (night lights, students may come up with more)

**C. How can you use the same circuit to help you in other areas of your life?** (allow students to come up with different and creative ways)

**Extension Activities:**

1. Students can use the same circuit and design an alarm clock that will go off when the sun comes up.
2. Students could use a different circuit, such as motion sensor, heat sensor, or a sensor for touch to create the same project stated above.
3. After constructing the circuit you could have students try to break into the box without having the alarm go off.

**Resources:**

Johnson, Dave . "Discover Circuits ." . 2004. Discover Circuits . 10/13/2004 <<http://www.discovercircuits.com/A/alarms.htm>>.

Price, Eric . "Alarm Circuit ." The Educator's Reference Desk . 08/24/2003. Fellowes High School . 10/16/2004 <<http://www.eduref.org/cgi-bin/printlessons.cgi/Virtual/Lessons/Science/Physics/PHS0212.html>>.

**Glossary:**

**Circuit-**

- A. A closed path followed or capable of being followed by an electric current.
- B. A configuration of electrically or electromagnetically connected components or devices.

## Sun-Up Circuit

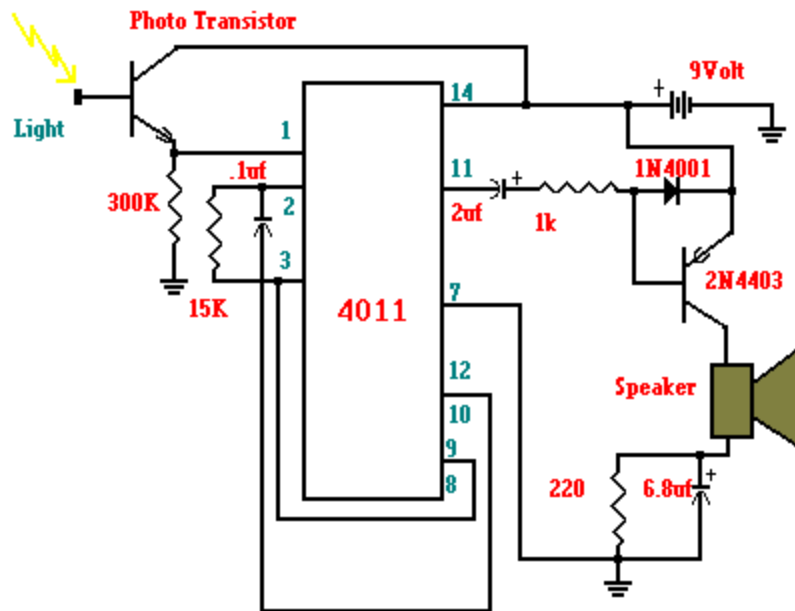

**Sun up Circuit-** The Sun - Up Alarm can be used to provide a audible alarm for when the sun comes up or it can be used in a dark area and detect when a light comes on. It can also be used to detect a light beam, headlights etc. The circuit works as follows. The phototransistor is very sensitive to light. (Any phototransistor will work fine) The sun shining on this device will provide a high to one of the NAND gates. This will cause another NAND gate to oscillate which will drive another NAND gate to output a 100hz tone. The transistor provides drive for the speaker. (Discover Circuits)